

Technical Data for **MCE-Series** Mass Flow Controllers

0.5 sccm full scale through 5 sccm full scale

Includes welded ¼" VCR® male fittings

SENSOR AND CONTROL PERFORMANCE	
Mass Flow Accuracy at calibration conditions ¹	±0.8% of reading and ±0.2% of full scale
High Accuracy Option ¹	±0.4% of reading and ±0.2% of full scale Available for ≥5 SCCM models
Repeatability (2σ)	±(0.2% of reading + 0.02% of full scale)
Steady State Control Range	0.01–100% of full scale
Typical Control Response Time	As fast as 100 ms, flow rate dependent, user adjustable
Valve Function	Normally Closed
Temperature Sensitivity	Mass flow zero and span shift: 0.02% of full scale per °C from 25°C
Pressure Sensitivity	Mass flow zero and span shift: ±(0.08% of reading + 0.02% of full scale) per atm from calibration conditions
Operating Temperature Range	–10–60°C
Temperature Accuracy	±0.75°C
Operating Pressure Full Scale	160 PSIA
Pressure Accuracy above 1 atm	±0.5% of reading
Pressure Accuracy below 1 atm	±0.07 PSIA
Totalizer Volume Uncertainty	±0.5% of reading in additional uncertainty
Sensor Response Time	<1 ms
Typical Indication Response Time	<10 ms, flow rate dependent
Typical Warm-Up Time	<1 s

¹ Stated accuracy is after tare under equilibrium conditions, includes repeatability and linearity.

MECHANICAL	
Minimum Operating Pressure	11.5 PSIA common mode pressure (consult Alicat for lower operating pressures). Differential pressure must exceed model pressure drop, see below for details.
Maximum Operating Pressure	Damage possible above 175 PSIA common mode pressure. Damage possible above 75 PSI differential pressure.
Ingress Protection	IP40
Humidity Range	0–95%, non-condensing
External Leak integrity	All devices are tested to external leak rates better than 1×10 ⁻⁹ atm-cc/sec
Internal Leak Integrity (Leak through the valve at zero set point)	Valves are tested to leak rates of 1×10 ⁻⁵ atm-cc/sec at zero set point
Wetted Materials	302, 303, 304, 316L, and 430FR stainless steel; FKM, alumina ceramic, brass, glass, gold, heat-cured epoxy, heat-cured silicone rubber, polyamide, silicon

FEATURES	
SEMI standard length	Matches 124 mm end-to-end length of SEMI standard MFCs
STP Reference Conditions	25°C and 1 atm (default), user configurable
NTP Reference Conditions	0°C and 1 atm (default), user configurable
Monochrome LCD or Color TFT Display with integrated touchpad	Simultaneously displays mass flow, volumetric flow, temperature, setpoint, and pressure
Gas Select™	98 user-selectable gases stored internally. Each gas optimized to match NIST's REFPROP 10 gas property calculations across the operating temperature and pressure ranges for highest accuracy.
COMPOSER™	20 user-definable gas mixes. Each mix may have up to 5 gases with 0.01% composition precision.

Technical Data for **MCE-Series** Mass Flow Controllers

0.5 sccm full scale through 5 sccm full scale

Includes welded 1/4" VCR® male fittings

CONTROL AND COMMUNICATIONS	
Analog I/O Options	4–20 mA, 0–5 VDC, 1–5 VDC, 0–10 VDC
Digital I/O Options	RS-232 Serial by default RS-485 Serial, Modbus RTU (over RS-232 or RS-485), Modbus TCP/IP, DeviceNet, EtherCAT, EtherNet/IP, Profibus
Electrical Connection Options	6-pin locking, 8-pin mini-DIN, 8-pin M12, DB-9, DB-15 (Contact Alicat for custom pinouts)
Power Requirements ²	12–24 VDC, 250 mA (290 mA if equipped with 4–20 mA output)
Digital Data Update Rate ²	40 Hz at 19200 baud
Analog Data Update Rate ²	1 kHz
Display Update Rate	10 Hz
Analog Signal Accuracy	±0.1% of full scale additional uncertainty

2 Consult the individual operating bulletins for specific industrial protocol power requirements and data transmission specifications.

RANGE-SPECIFIC TECHNICAL DATA			
Full scale flow	Pressure drop at full scale flow ³	Process connections ⁴	Mount hole size
0.5 SCCM–5 SCCM	1.0 PSID	1/4" VCR® Male	4× obround pass-through slots, ø 0.188" × 0.4" [4.78 mm × 10.16 mm]

3 Default valve venting air to atmosphere. Other valves may be available.

4 Swagelok® tube and VCO® process connections are also available.

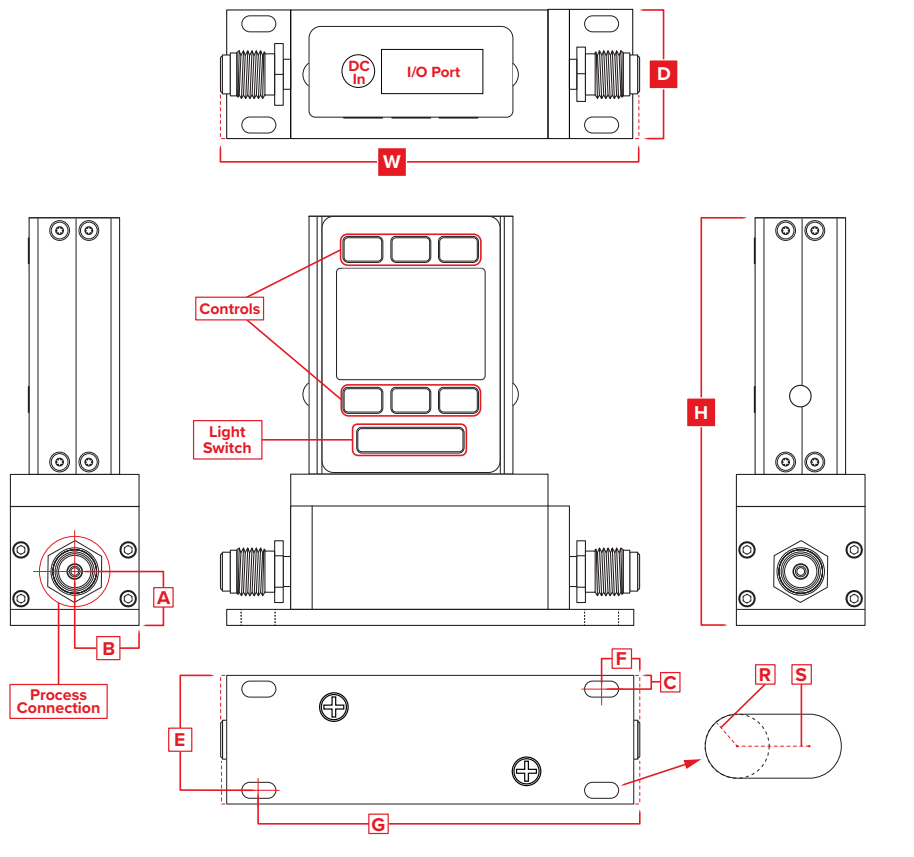

Representative Example

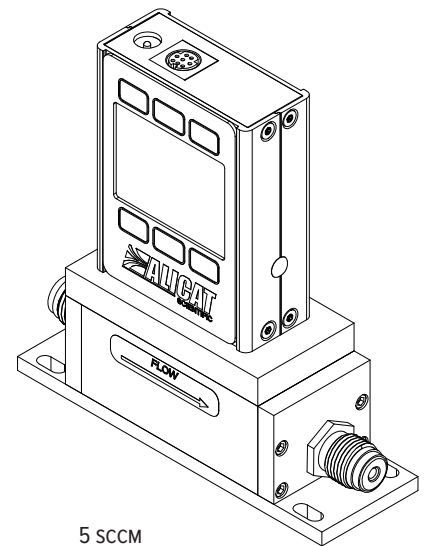

5 SCCM

Full scale flow	DIMENSIONS											WEIGHT
	Height	Width	Depth	A	B	C	E	F	G	R	S	
0.5–5 SCCM	4.755 in	4.882 in	1.500 in	0.628 in	0.750 in	0.161 in	1.339 in	0.373 in	4.373 in	0.094 in	0.212 in	≈ 2.3 lb
	120.78 mm	124.00 mm	38.10 mm	15.95 mm	19.05 mm	4.09 mm	34.01 mm	9.47 mm	111.07 mm	2.39 mm	5.38 mm	≈ 1.0 kg