

Technical Data for **MCVS-Series** Mass Flow Controllers

0.5 sccm full scale through 20 SLPM full scale

Includes Swagelok® positive shutoff valve for maintaining vacuum integrity

SENSOR AND CONTROL PERFORMANCE	
Mass Flow Accuracy at Calibration Conditions ¹	±0.8% of reading and ±0.2% of full scale
High Accuracy Option ¹	±0.4% of reading and ±0.2% of full scale Available for ranges ≥5 SCCM models
Repeatability	±0.2% of full scale
Steady State Control Range	1–100% of full scale
Typical Control Response Time	0.5 SCCM–5 SCCM: As fast as 100 ms, flow rate dependent, user adjustable 10 SCCM–20 SLPM: As fast as 30 ms, flow rate dependent, user adjustable
Valve Function	Normally Closed
Temperature Sensitivity	Mass flow zero shift: ±0.02% of full scale per °C from tare temperature Mass flow span shift: ±0.02% of reading per °C from 25°C
Pressure Sensitivity	Mass flow zero shift: ±0.02% of full scale per atm from tare pressure Mass flow span shift: ±(0.08% of reading + 0.02% of full scale) per atm from calibration conditions
Operating Temperature Range	–10–60°C
Temperature Accuracy	±0.75°C
Operating Pressure Full Scale	160 PSIA
Pressure Accuracy	±0.5% of full scale
Totalizer Volume Uncertainty	±0.5% of reading in additional uncertainty
Sensor Response Time	<1 ms
Typical Indication Response Time	<10 ms, flow rate dependent
Typical Warm-Up Time	<1 s

¹ Stated accuracy is after tare under equilibrium conditions, includes repeatability and linearity.

MECHANICAL	
Minimum Operating Pressure	11.5 PSIA common mode pressure (consult Alicat for lower operating pressures) Differential pressure must exceed model pressure drop, see below for details
Maximum Operating Pressure	Damage possible above 200 PSIA common mode pressure Damage possible above 75 PSI differential pressure
Ingress Protection	IP40
Humidity Range	0–95%, non-condensing
Leak Integrity, External	1×10 ⁻⁸ atm-cc/sec of Helium
Swagelok® Shutoff Valve Leak Integrity	1×10 ⁻⁹ atm-cc/sec of Helium
Wetted Materials	303, 316L, and 430FR stainless steel; FFKM

FEATURES	
Swagelok® Shutoff Valve	Pneumatically actuated (>60 PSIG source needed), normally closed, positive shutoff valve to ensure no leak through
STP Reference Conditions	25°C and 1 atm (default), user configurable
NTP Reference Conditions	0°C and 1 atm (default), user configurable
Monochrome LCD or Color TFT Display with Integrated Touchpad	Simultaneously displays mass flow, volumetric flow, temperature, setpoint, and pressure
Gas Select™	128 user-selectable gases stored internally. Each gas optimized to match NIST's REFPROP 10 gas property calculations across the operating temperature and pressure ranges for highest accuracy.
COMPOSER™	20 user-definable gas mixes. Each mix may have up to 5 gases with 0.01% composition precision.

Technical Data for **MCVS-Series** Mass Flow Controllers

0.5 sccm full scale through **20 SLPM** full scale

Includes Swagelok® positive shutoff valve for maintaining vacuum integrity

COMMUNICATIONS	
Analog I/O Options	4–20 mA, 0–5 Vdc, 1–5 Vdc, 0–10 Vdc
Digital I/O Options	RS-232 serial by default RS-485 serial, Modbus RTU (over RS-232 or RS-485 serial), Modbus TCP/IP, DeviceNet, EtherCAT, EtherNet/IP, PROFIBUS
Electrical Connection Options	6-pin locking, 8-pin mini-DIN, 8-pin M12, DB-9, DB-15 (Contact Alicat for custom pinouts)
Power Requirements ²	12–24 Vdc, 250 mA (290 mA if equipped with 4–20 mA output)
Digital Data Update Rate ²	40 Hz at 19200 baud
Analog Data Update Rate ²	1 kHz
Display Update Rate	10 Hz
Analog Signal Accuracy	±0.1% of full scale additional uncertainty

2 Consult the individual operating bulletins for specific industrial protocol power requirements and data transmission specifications.

This area intentionally left blank

Technical Data for **MCVS-Series** Mass Flow Controllers

0.5 sccm full scale through 20 SLPM full scale

Includes Swagelok® positive shutoff valve for maintaining vacuum integrity

RANGE-SPECIFIC TECHNICAL DATA			
Full scale flow	Pressure drop at full scale flow ³	Process connections ⁴	Mount hole size
0.5 sccm–500 sccm	1.0 PSID	¼" VCR®-compatible male	4× pass-through holes, ø 0.240" [6.10 mm]
1 SLPM	1.5 PSID	¼" VCR®-compatible male	4× pass-through holes, ø 0.240" [6.10 mm]
2 SLPM	3.0 PSID	¼" VCR®-compatible male	4× pass-through holes, ø 0.240" [6.10 mm]
5 SLPM	2.0 PSID	¼" VCR®-compatible male	4× pass-through holes, ø 0.240" [6.10 mm]
10 SLPM	5.5 PSID	¼" VCR®-compatible male	4× pass-through holes, ø 0.240" [6.10 mm]
20 SLPM	20.0 PSID	¼" VCR®-compatible male	4× pass-through holes, ø 0.240" [6.10 mm]

3 Default valve venting air to atmosphere.

4 Compression and Swagelok® VCO® process connections are also available.

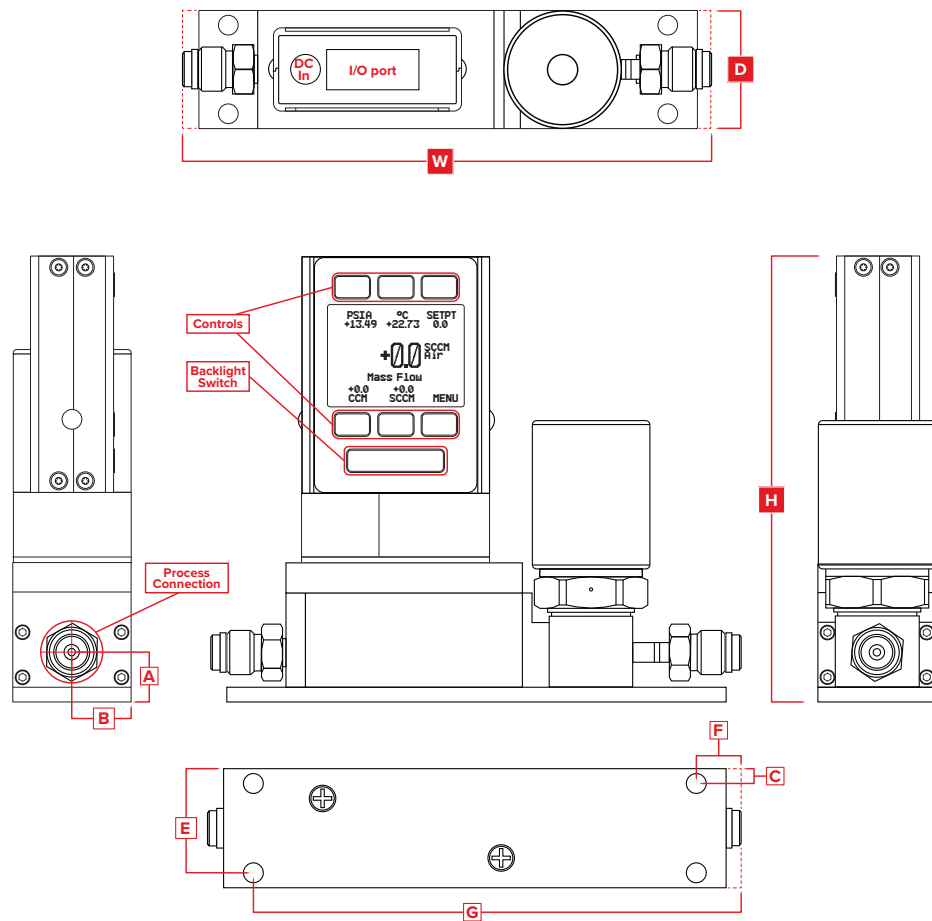

Representative Example

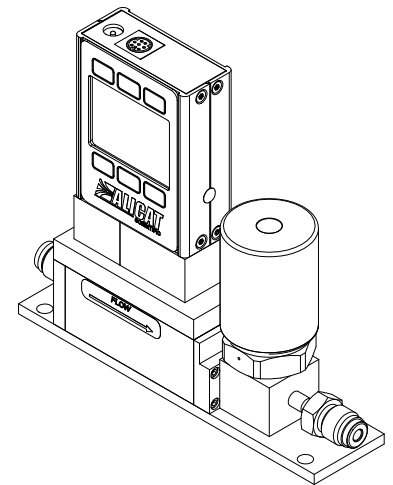

20 SLPM

DIMENSIONS										WEIGHT
Full scale flow	Height	Width	Depth	A	B	C	E	F	G	
0.5 sccm–20 SLPM	5.555 in	6.722 in	1.500 in	0.628 in	0.750 in	0.188 in	1.313 in	0.375 in	5.955 in	≈ 3.3 lb
	141.10 mm	170.74 mm	38.10 mm	15.95 mm	19.05 mm	4.78 mm	33.35 mm	9.53 mm	151.26 mm	≈ 1.5 kg