



Precision Flow Control for Bioreactors

 **ALICAT**
SCIENTIFIC
BIO SERIES

Everything you need

Nothing you don't

Reliable, Adaptable and Compatible Flow Control

- **Extremely low zero drift** ensures long term measurement stability
- **Resistance to process water contamination** with a lifetime warranty
- **High contrast ultra-sharp color display**
- ASME recommended materials including **316L stainless steel** and USP Class VI FDA-grade certified elastomers
- **"Gas Select"** feature enables exchange of controller gasses without re-calibration or loss of accuracy
- **"Drive Display"** for monitoring of in-line process health and control performance



Flexible configuration, customized for your needs

- Built with your preferred **industrial protocols and Pharma 4.0** in mind
- **Wide range of flow rates** – from 1SCCM up to 5000SLPM
- **Controllable ranges exceeding 2000:1** eliminate the need for multiple gas lines
- Ultra-fast **10ms response times** enable high speed data logging and control
- **On-site calibration** tools available – Never return a unit
- **Flexible process connections** (SAE standard)

Wide range flow rates and compatibility with multiple gasses eliminates unnecessary piping

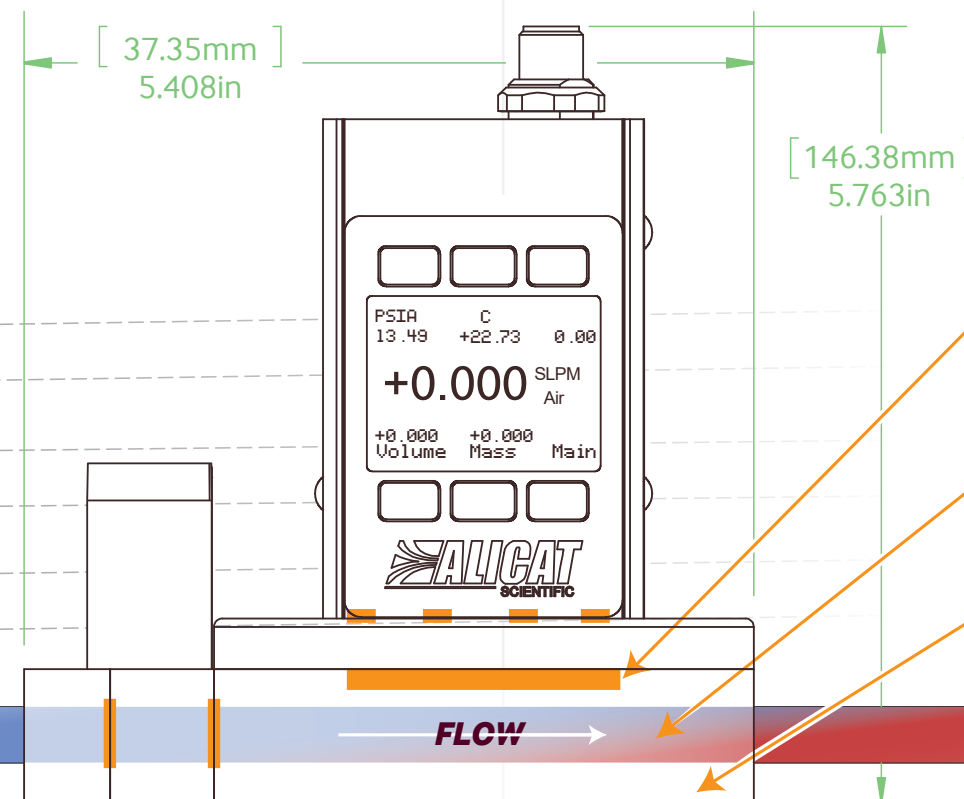
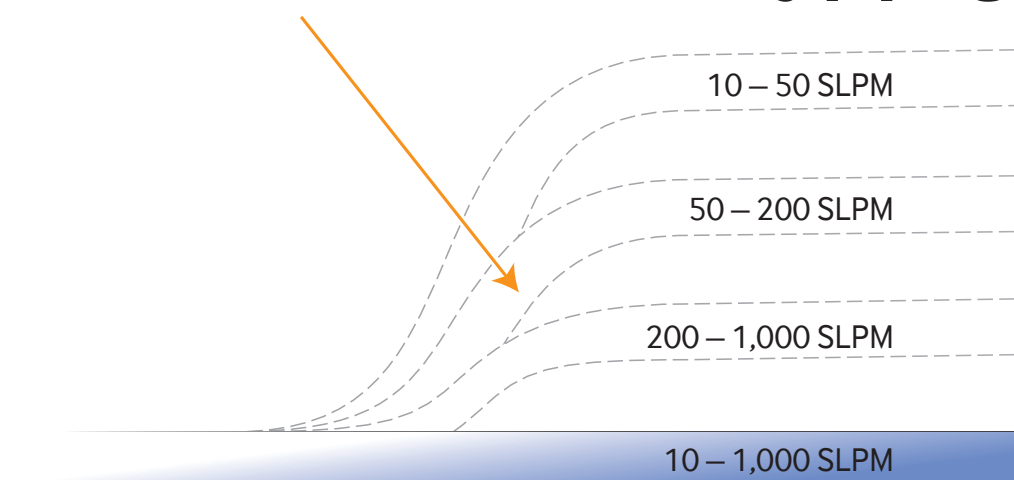

FDA-grade elastomers prevent contamination

Backflow tolerance with zero calibration drift

316L stainless steel for durability and stability, with a lifetime warranty