

Design Features

- Easy to read English or metric scales.
- Interchangeable scales for routine gases.
- Customer convertible panel to partial or full in-line mounted configurations.
- Panel mounting by means of hex nuts.
- Meters offered with or without built-in low hysteresis needle valves.
- Easy disassembly and assembly for cleaning.

OPTIONAL PRODUCTS

FLOW METER KITS ARE AVAILABLE WITH DIRECT READING SCALES DISPLAYING: AIR, WATER, ARGON, NITROGEN, HELIUM, CARBON DIOXIDE, AND OXYGEN IN BOTH ENGLISH AND METRIC UNITS.



**Panel Mounting
Meter with Built In
Needle Valve**



Typical In-Line Meter

Superior Quality . . .

. . . Stable, Easy to Read Float

DIMENSIONS

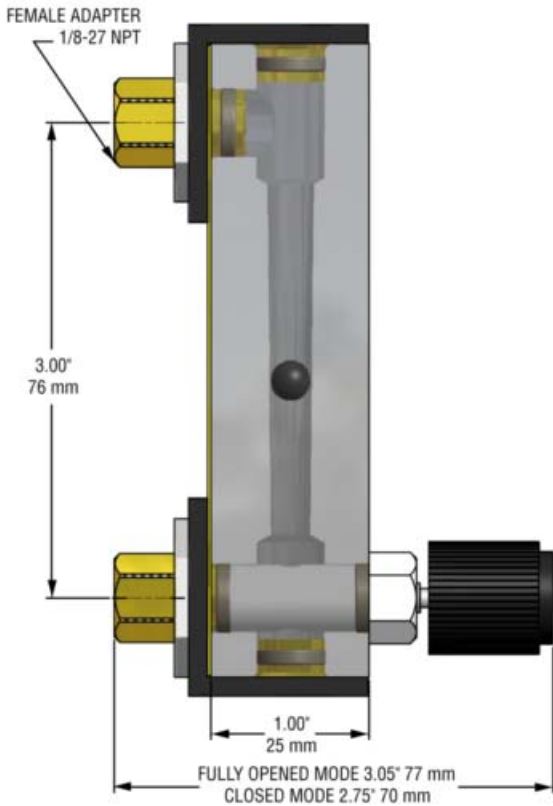
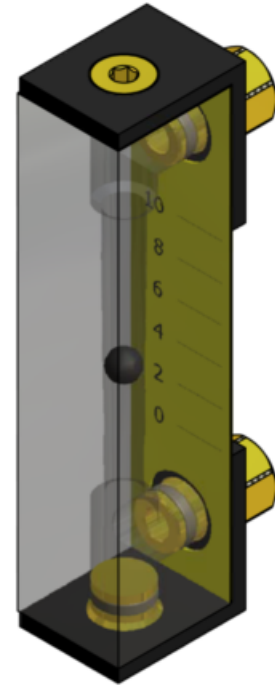
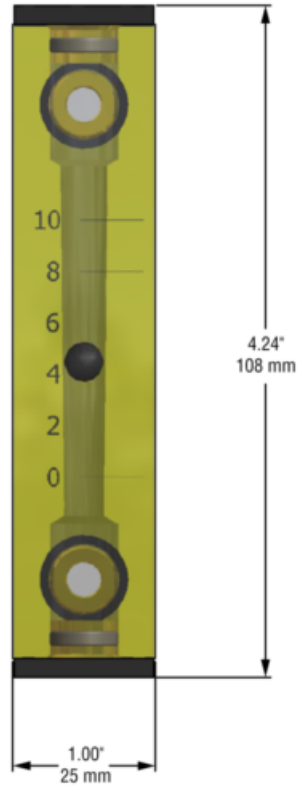
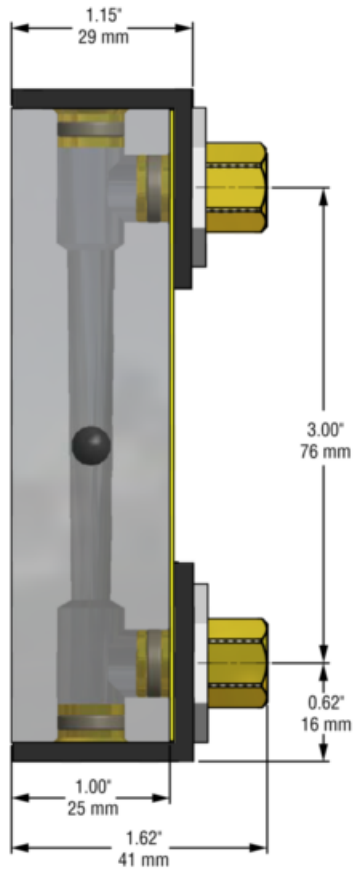

ACR SPECIFICATIONS

ACCURACY:	±5% of full scale reading.
MAXIMUM TEMPERATURE:	65°C (150°F).
MAXIMUM PRESSURE:	6.9 bars (100 psig).
METER BLOCK:	Clear machined acrylic.
FLOAT MATERIALS:	Black Glass, stainless steel, Tungsten Carbide.
O-RING SEALS:	Viton®
FITTINGS:	Brass or stainless 1/8" NPT female connections, built-in needle valves and seal plugs.

AIR FLOW METERS WITH DIRECT READING SCALES					
MODEL NO.	FITTING MATERIAL	VALVE OPTION	DUAL SCALE		FLOAT MATERIAL
			L/min	SCFH	
ACRZB0V01	BRASS	NO	1.4	2.8	GLASS
ACRZB1V01		YES			
ACRZS0V01	STAINLESS	NO	2.75	5.5	STAINLESS
ACRZS1V01		YES			
ACRZB0V08	BRASS	NO	3.5	7.0	CARBOLOY
ACRZB1V08		YES			
ACRZS0V08	STAINLESS	NO	8.5	18.0	GLASS
ACRZS1V08		YES			
ACRZB0V15	BRASS	NO	16.0	32.5	STAINLESS
ACRZB1V15		YES			
ACRZS0V15	STAINLESS	NO	22.0	45.0	CARBOLOY
ACRZS1V15		YES			
ACRYB0V01	BRASS	NO	50	100	STAINLESS
ACRYB1V01		YES			
ACRYB0V08	BRASS	NO	5	10	GLASS
ACRYB1V08		YES			
ACRYB0V15	BRASS	NO	15.0	30.0	STAINLESS
ACRYB1V15		YES			
ACRYB0V22	BRASS	NO	20.0	42.5	CARBOLOY
ACRYB1V22		YES			
ACRYB0V28	BRASS	NO	45	90	STAINLESS
ACRYB1V28		YES			

OXYGEN FLOW METERS WITH DIRECT READING SCALES					
MODEL NO.	FITTING MATERIAL	VALVE OPTION	DUAL SCALE		FLOAT MATERIAL
			L/min	SCFH	
ACRZB0V07	BRASS	NO	1.2	2.5	GLASS
ACRZB1V07		YES			
ACRZS0V07	STAINLESS	NO	2.50	5.0	STAINLESS
ACRZS1V07		YES			
ACRZB0V21	BRASS	NO	3.5	7.0	CARBOLOY
ACRZB1V21		YES			
ACRZS0V21	STAINLESS	NO	8.0	16.0	GLASS
ACRZS1V21		YES			
ACRYB0V07	BRASS	NO	15.0	30.0	STAINLESS
ACRYB1V07		YES			
ACRYB0V14	BRASS	NO	20.0	42.5	CARBOLOY
ACRYB1V14		YES			
ACRYB0V21	BRASS	NO	45	90	STAINLESS
ACRYB1V21		YES			

NITROGEN FLOW METERS WITH DIRECT READING SCALES					
MODEL NO.	FITTING MATERIAL	VALVE OPTION	DUAL SCALE		FLOAT MATERIAL
			L/min	SCFH	
ACRZB0V06	BRASS	NO	1.3	2.75	GLASS
ACRZB1V06		YES			
ACRZS0V06	STAINLESS	NO	2.75	5.5	STAINLESS
ACRZS1V06		YES			
ACRZB0V13	BRASS	NO	3.5	7.5	CARBOLOY
ACRZB1V13		YES			
ACRZS0V13	STAINLESS	NO	8.0	16.0	GLASS
ACRZS1V13		YES			
ACRZB0V20	BRASS	NO	16.0	32.5	STAINLESS
ACRZB1V20		YES			
ACRZS0V20	STAINLESS	NO	22.0	45.0	CARBOLOY
ACRZS1V20		YES			
ACRYB0V06	BRASS	NO	45	100	STAINLESS
ACRYB1V06		YES			
ACRYB0V13	BRASS	NO	5	10	GLASS
ACRYB1V13		YES			
ACRYB0V20	BRASS	NO	15.0	30.0	STAINLESS
ACRYB1V20		YES			
ACRYB0V27	BRASS	NO	20.0	42.5	CARBOLOY
ACRYB1V27		YES			

CARBON DIOXIDE FLOW METERS WITH DIRECT READING SCALES					
MODEL NO.	FITTING MATERIAL	VALVE OPTION	DUAL SCALE		FLOAT MATERIAL
			L/min	SCFH	
ACRZB0V04	BRASS	NO	1.1	2.2	GLASS
ACRZB1V04		YES			
ACRZS0V04	STAINLESS	NO	2.0	5.0	STAINLESS
ACRZS1V04		YES			
ACRZB0V11	BRASS	NO	3.0	6.5	CARBOLOY
ACRZB1V11		YES			
ACRZS0V11	STAINLESS	NO	7.0	15.0	GLASS
ACRZS1V11		YES			
ACRZB0V18	BRASS	NO	12.0	25.0	STAINLESS
ACRZB1V18		YES			
ACRZS0V18	STAINLESS	NO	18.0	37.5	CARBOLOY
ACRZS1V18		YES			
ACRYB0V04	BRASS	NO	35	80	STAINLESS
ACRYB1V04		YES			
ACRYB0V11	BRASS	NO	5	10	GLASS
ACRYB1V11		YES			
ACRYB0V18	BRASS	NO	15.0	30.0	STAINLESS
ACRYB1V18		YES			



ACRYLIC FLOW METERS

ARGON FLOW METERS WITH DIRECT READING SCALES

MODEL NO.	FITTING MATERIAL	VALVE OPTION	DUAL SCALE		FLOAT MATERIAL
			L/min	SCFH	
ACRZB0V03	BRASS	NO	1.1	2.25	GLASS
ACRZB1V03		YES			
ACRZS0V03	STAINLESS	NO			
ACRZS1V03		YES			
ACRZB0V10	BRASS	NO	2.2	5.0	STAINLESS
ACRZB1V10		YES			
ACRZS0V10	STAINLESS	NO			
ACRZS1V10		YES			
ACRZB0V17	BRASS	NO	3.0	6.5	CARBOLOY
ACRZB1V17		YES			
ACRZS0V17	STAINLESS	NO			
ACRZS1V17		YES			
ACRYB0V03	BRASS	NO	7.0	15.0	GLASS
ACRYB1V03		YES			
ACRYS0V03	STAINLESS	NO			
ACRYS1V03		YES			
ACRYB0V10	BRASS	NO	13.0	26.0	STAINLESS
ACRYB1V10		YES			
ACRYS0V10	STAINLESS	NO			
ACRYS1V10		YES			
ACRYB0V17	BRASS	NO	18.0	37.5	CARBOLOY
ACRYB1V17		YES			
ACRYS0V17	STAINLESS	NO			
ACRYS1V17		YES			
ACRYB0V24	BRASS	NO	40	80	STAINLESS
ACRYB1V24		YES			
ACRYS0V24	STAINLESS	NO			
ACRYS1V24		YES			

WATER FLOW METERS WITH DIRECT READING SCALES

MODEL NO.	FITTING MATERIAL	VALVE OPTION	DUAL SCALE		FLOAT MATERIAL
			mL/min	GAL/H	
ACRZB0V02	BRASS	NO	20.0	0.3	GLASS
ACRZB1V02		YES			
ACRZS0V02	STAINLESS	NO			
ACRZS1V02		YES			
ACRZB0V09	BRASS	NO	70.0	1.1	STAINLESS
ACRZB1V09		YES			
ACRZS0V09	STAINLESS	NO			
ACRZS1V09		YES			
ACRZB0V16	BRASS	NO	100.0	1.5	CARBOLOY
ACRZB1V16		YES			
ACRZS0V16	STAINLESS	NO			
ACRZS1V16		YES			
ACRYB0V02	BRASS	NO	175.0	2.75	GLASS
ACRYB1V02		YES			
ACRYS0V02	STAINLESS	NO			
ACRYS1V02		YES			
ACRYB0V09	BRASS	NO	450.0	6.5	STAINLESS
ACRYB1V09		YES			
ACRYS0V09	STAINLESS	NO			
ACRYS1V09		YES			
ACRYB0V16	BRASS	NO	700.0	11.0	CARBOLOY
ACRYB1V16		YES			
ACRYS0V16	STAINLESS	NO			
ACRYS1V16		YES			
ACRYB0V23	BRASS	NO	1400	22	STAINLESS
ACRYB1V23		YES			
ACRYS0V23	STAINLESS	NO			
ACRYS1V23		YES			

HELIUM FLOW METERS WITH DIRECT READING SCALES

MODEL NO.	FITTING MATERIAL	VALVE OPTION	DUAL SCALE		FLOAT MATERIAL
			L/min	SCFH	
ACRZB0V05	BRASS	NO	2.0	4.0	GLASS
ACRZB1V05		YES			
ACRZS0V05	STAINLESS	NO			
ACRZS1V05		YES			
ACRZB0V12	BRASS	NO	5.5	11.0	STAINLESS
ACRZB1V12		YES			
ACRZS0V12	STAINLESS	NO			
ACRZS1V12		YES			
ACRZB0V19	BRASS	NO	8.0	17.0	CARBOLOY
ACRZB1V19		YES			
ACRZS0V19	STAINLESS	NO			
ACRZS1V19		YES			
ACRYB0V05	BRASS	NO	18.0	40.0	GLASS
ACRYB1V05		YES			
ACRYS0V05	STAINLESS	NO			
ACRYS1V05		YES			
ACRYB0V12	BRASS	NO	35.0	70.0	STAINLESS
ACRYB1V12		YES			
ACRYS0V12	STAINLESS	NO			
ACRYS1V12		YES			
ACRYB0V19	BRASS	NO	55.0	110.0	CARBOLOY
ACRYB1V19		YES			
ACRYS0V19	STAINLESS	NO			
ACRYS1V19		YES			
ACRYB0V26	BRASS	NO	110	250	STAINLESS
ACRYB1V26		YES			
ACRYS0V26	STAINLESS	NO			
ACRYS1V26		YES			



ACRYLIC FLOW METER KITS WITH DIRECT READING SCALES

Kits include an air meter and six interchangeable direct reading dual scales: Argon, Carbon Dioxide, Helium, Nitrogen, Oxygen, and Water.

ACRYLIC FLOW METER KITS																																
MODEL NO.	FITTING MATERIAL	VALVE OPTION	DUAL SCALES														FLOAT MATERIAL															
			AIR		WATER		ARGON		CARBON DIOXIDE		HELIUM		NITROGEN		OXYGEN																	
			L/min	SCFH	mL/min	GAL/H	L/min	SCFH	L/min	SCFH	L/min	SCFH	L/min	SCFH	L/min	SCFH																
ACRZB0VK1	BRASS	NO	1.4	2.8	20.0	0.3	1.1	2.25	1.1	2.5	2.0	4.0	1.3	2.75	1.2	2.5	GLASS															
ACRZB1VK1		YES																														
ACRZS0VK1	STAINLESS	NO																														
ACRZS1VK1		YES																														
ACRZB0VK3	BRASS	NO																2.75	5.5	70.0	1.1	2.2	5.0	2.0	5.0	5.5	11.0	2.75	5.5	2.50	5.0	STAINLESS
ACRZB1VK3		YES																														
ACRZS0VK3	STAINLESS	NO																														
ACRZS1VK3		YES																														
ACRZB0VK4	BRASS	NO	3.5	7.0	100.00	1.5	3.0	6.5	3.0	6.5	8.0	17.0	3.5	7.5	3.5	7.0	CARBOLOY															
ACRZB1VK4		YES																														
ACRZS0VK4	STAINLESS	NO																														
ACRZS1VK4		YES																														
ACRYB0VK1	BRASS	NO																8.5	18.0	175.0	2.75	7.0	15.0	7.0	15.0	18.0	40.0	8.0	16.0	8.0	16.0	GLASS
ACRYB1VK1		YES																														
ACRYS0VK1	STAINLESS	NO																														
ACRYS1VK1		YES																														
ACRYB0VK3	BRASS	NO	16.0	32.5	450.0	6.5	13.0	26.0	12.0	25.0	35.0	70.0	16.0	32.5	15.0	30.0	STAINLESS															
ACRYB1VK3		YES																														
ACRYS0VK3	STAINLESS	NO																														
ACRYS1VK3		YES																														
ACRYB0VK4	BRASS	NO																22.0	45.0	700.0	11.0	18.0	37.5	18.0	37.5	55.0	110.0	22.0	45.0	20.0	42.5	CARBOLOY
ACRYB1VK4		YES																														
ACRYS0VK4	STAINLESS	NO																														
ACRYS1VK4		YES																														
ACRYB0VK6	BRASS	NO	50	100	1400	22	40	80	35	80	110	250	45	100	45	90	STAINLESS															
ACRYB1VK6		YES																														
ACRYS0VK6	STAINLESS	NO																														
ACRYS1VK6		YES																														