

金屬管面積式流量計

METAL TUBE VARIABLE AREA TYPE FLOW METER

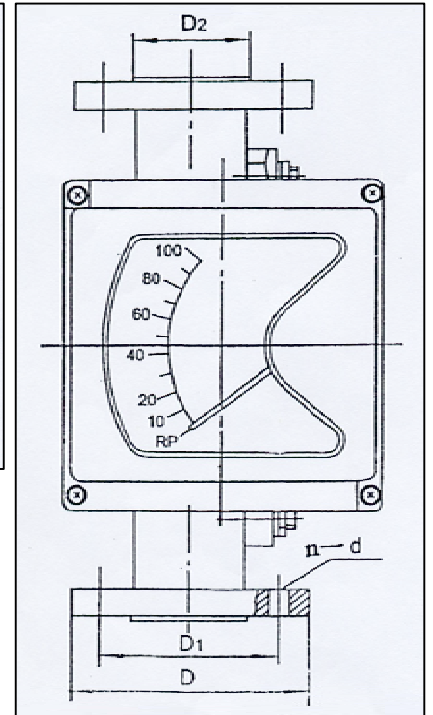
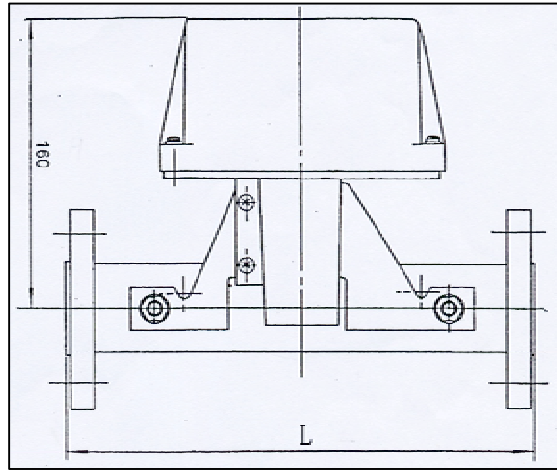

型號: HFC(指針式)

流體: 水或其他透明、不透明液體，空氣或其他氣體

接續: 垂直安裝，下進上出

口徑: Flange: 15A~200A JIS. DIN. ANSI

材質: 1. 本體-304SS 316SS 3. 浮球-304SS 316SS
 2. 內管-304SS 316SS 4. 外箱-Aluminium or 304SS

溫度: MAX 300 °C

壓力: MAX 70kg/cm² (價格因耐壓之大小而改變)

RANGE SIZE	Water M ³ /Hr	Air NM ³ /Hr	DIMENSION	
			L	F
HFC-15	0.1-1	1-12	250	1/2
HFC-20	0.2-2	2-20	250	3/4
HFC-25	0.3-3	5-50	250	1
HFC-32	0.6-6	10-100	250	1 1/4
HFC-40	1.2-12	20-200	250	1 1/2
HFC-50	2-20	30-300	250	2
HFC-65	3-30	40-400	250	2 1/2
HFC-80	5-50	50-500	300	3
HFC-100	7-70	60-600	300	4
HFC-125	10-100	80-800	300	5
HFC-150	15-150	100-1000	300	6
HFC-200	20-200	150-1500	300	8

歡迎訂製各式流量計，
敬請惠予告知下列條件:

1. 型式(Model)
2. 流體(Fluid)
3. 材質(Material)
4. 流量範圍(Flow Range)
5. 接續方式(Connection)
6. 操作壓力(Operating pressure)
7. 操作溫度(Operating temperature)
8. 濃度及黏度
(Concentration & Viscosity)
9. 比重或密度
(Specific Gravity & Density)

Remark: The above specifications will be revised any time without prior notification.